

HA006B

Payload 6Kgf

Installation method		Application	
Floor	●	Spot welding	●
Ceiling	●	Arc welding	●
Wall surface	●	Handling	●
		Assembly	●
		Sealing	●
		Painting	●

Item		Specification	
Robot model		HA006B	
Payload		6 Kg	
Structure		Articulated	
Degree of freedom		6 axes	
Drive system		AC SERVO MOTOR	
Max. working envelope	Arm	S Swivel	±3.00 rad (±172°)
		H Horizontal	+3.14 ~ -1.36 rad (+180° ~ -78°)
		V Vertical	+3.14 ~ -1.43 rad (+180° ~ -82°)
	Wrist	R2 Rotation 2	±3.14 rad (±180°)
		B Bending	±2.356 rad (±135°)
Max. working speed	Arm	S Swivel	4.01 rad / s (230° / s)
		H Horizontal	4.01 rad / s (230° / s)
		V Vertical	4.01 rad / s (230° / s)
	Wrist	R2 Rotation 2	7.50 rad / s (430° / s)
		B Bending	7.50 rad / s (430° / s)
Wrist torque	R2 Rotation 2	11.17 rad / s (640° / s)	
	B Bending	11.8 Nm (1.2 Kgfm)	
	R1 Rotation 1	9.8 Nm (1.0 Kgfm)	
Accuracy of position repeatability		±0.05 mm	
Ambient Temperature		0 ~ 45 °C (273 ~ 318 K)	
Robot's Weight		145 Kg	
Working envelope section area		3.16 m ²	

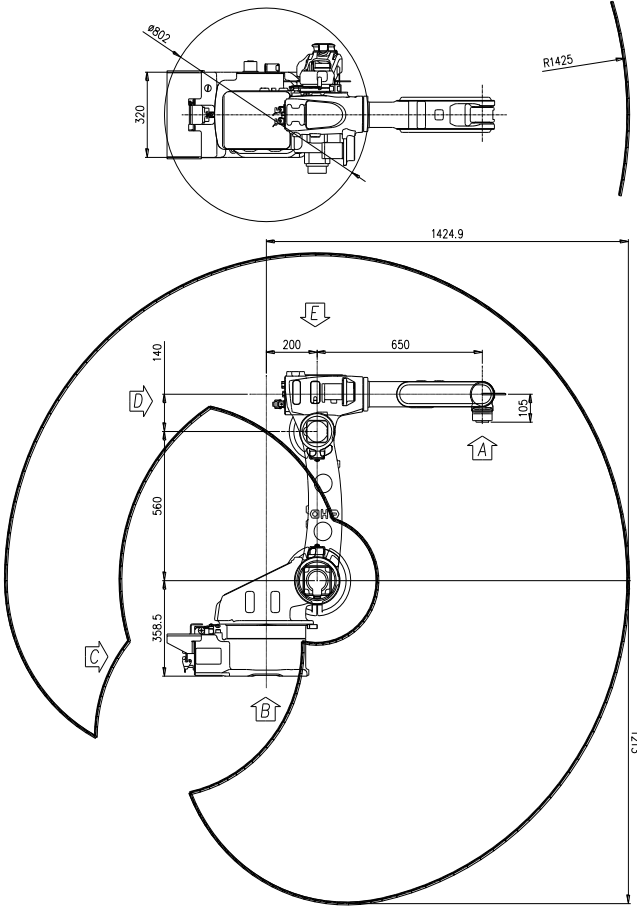

View A: Detailed drawing of the wrist attachment part

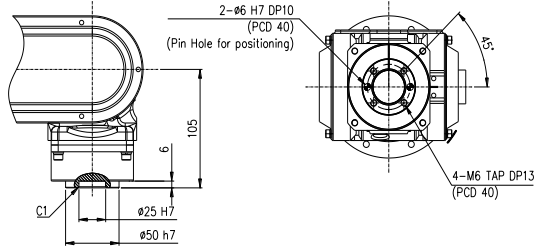

View B: Dimensional drawing for the floor installation of the body

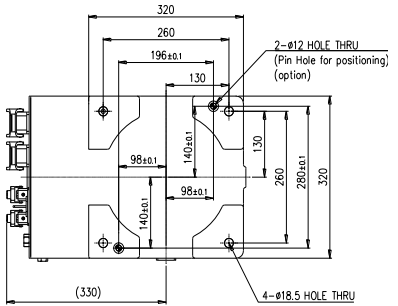

Wrist-axis torque line diagram

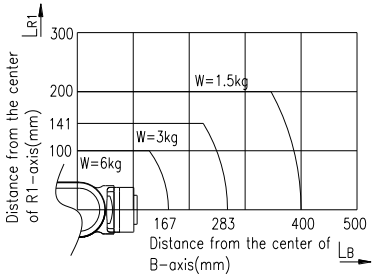

View C: Application cable connection part

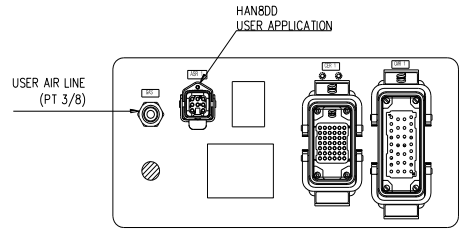

View D: Application cable connection part

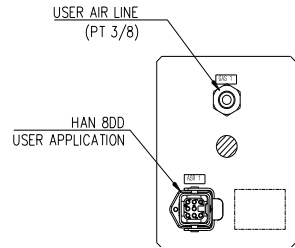

View E: Details of the application ancillary part attachment

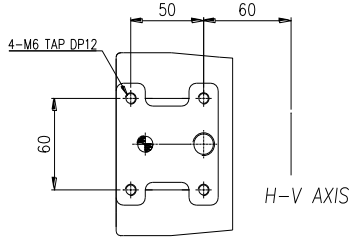

** For product improvement, some of the ratings, specifications, dimensions, etc. are subject to changes without notice.

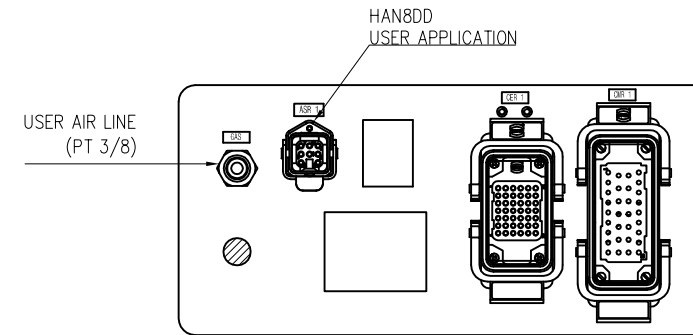
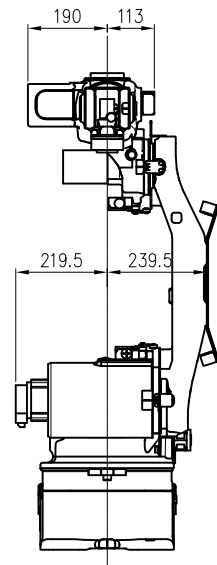
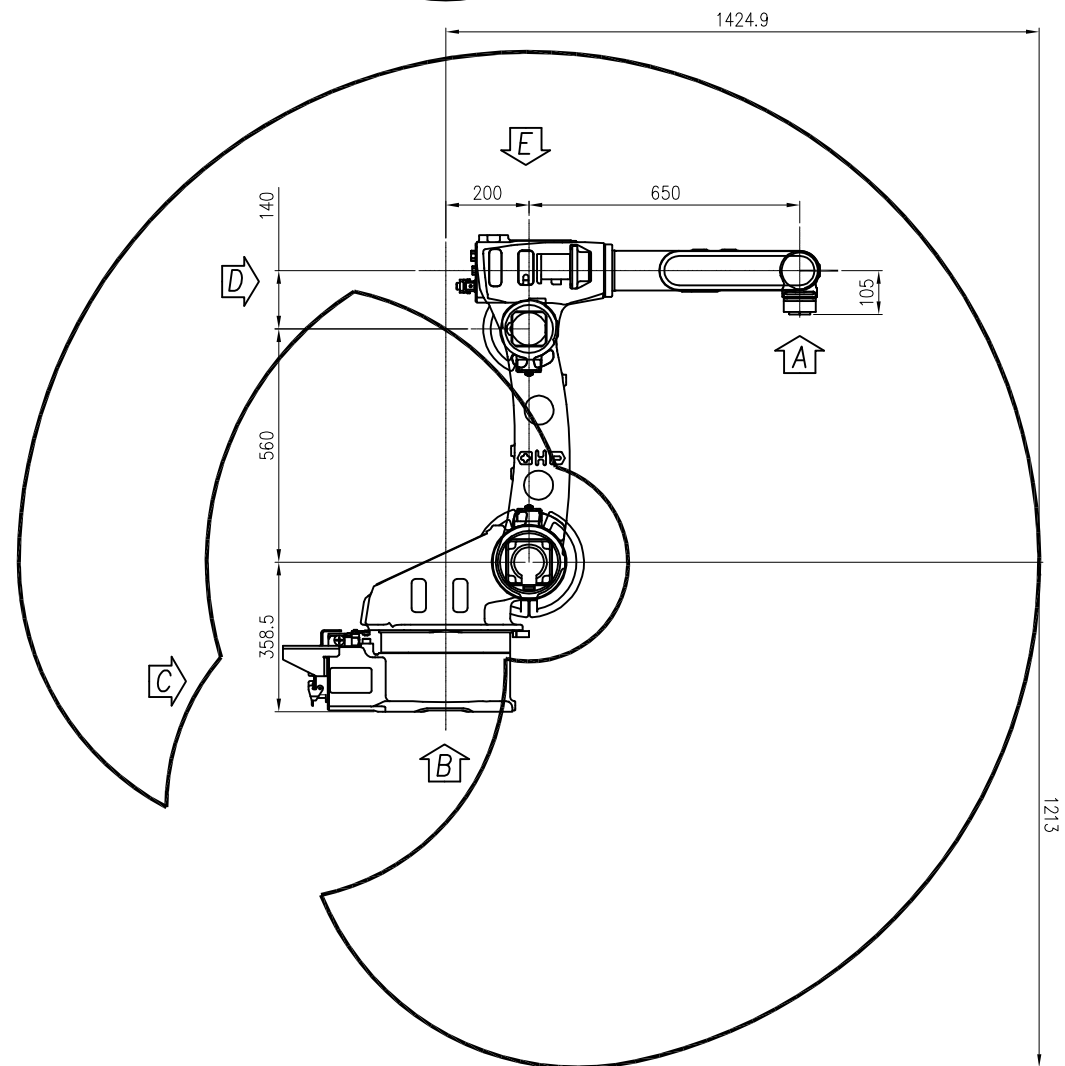
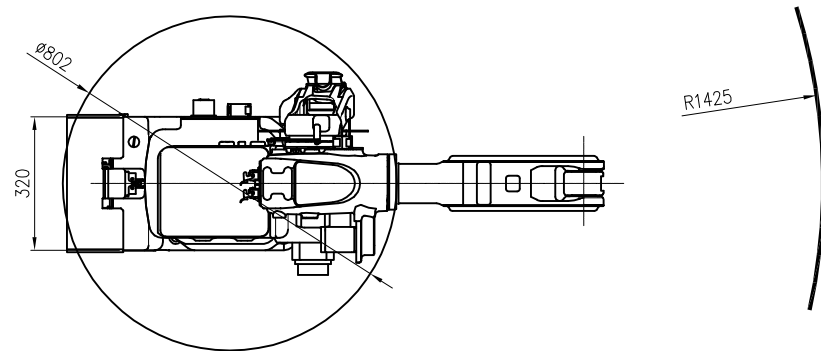
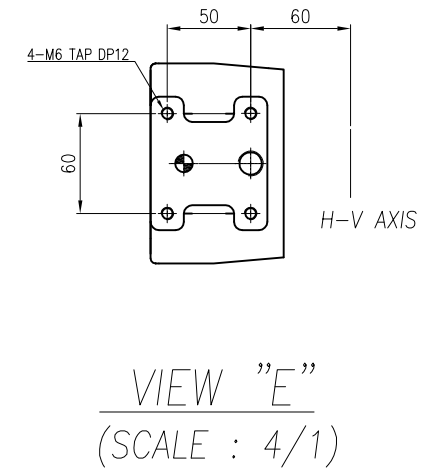
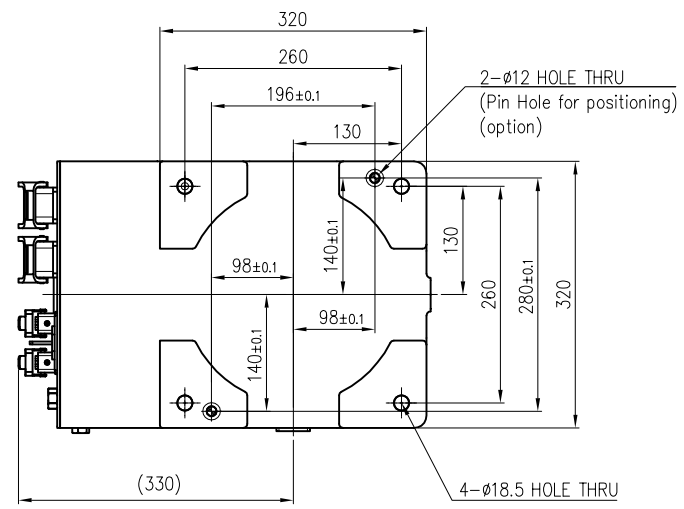
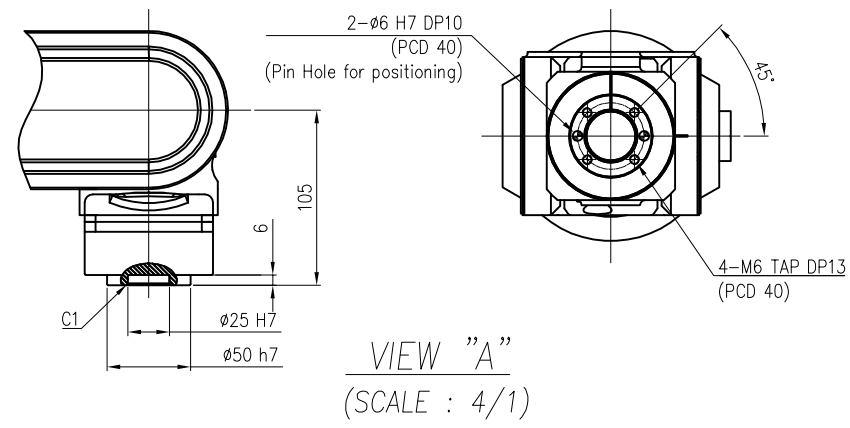

* ASR2 / AIR HOSE OPTION화

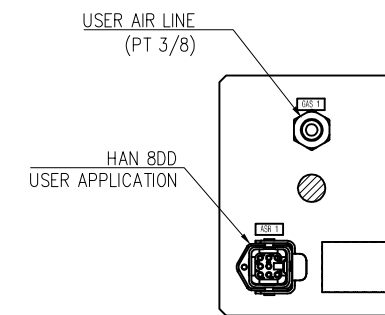

TECHNICAL SPECIFICATION SUBJECT TO
CHANGE WITHOUT NOTICE

MODEL	HA006B	issue.0
DATE	2018.06.19	

 **HYUNDAI ROBOTICS**